

Series 17

Butterfly Valve



Valves, Automation & Controls

Features

- 200 psi rating (2" - 12")
125 psi rating PTFE seat (2" - 12")
150 psi rating (14" - 48")
- Dead end service (lug only)
- Bidirectional
- MSS SP-67
- For use with Class 125 or 150 flanges
- Can be used with ASME B16.5 flanges with out separation gaskets
- ISO 5211 mounting pad
- Shaft and disc operate with out taper pins (2" - 12")
- MSS SP-25 markings
- Epoxy coated
- Undercut disc available (50 psi)

Seat Material	Temperature Rating °F	Seat Material	Temperature Rating °F
EPDM (2" - 16")	-30 to +275	PTFE	+10 to +275
EPDM (18" - 48")	-30 to +225	Hypalon	+10 to 150
EPDM Food Grade	-30 to +225	Viton	0 to +275
Buna-N	+10 to +180	High Temp Viton	+10 to +400



SHARPE - SERIES 17 | BUTTERFLY VALVE
 Toll Free (877) 774-2773 | Local (708) 562-9221 | Fax (708) 562-0890 | www.sharpevalves.com

2" - 12" Dimensions

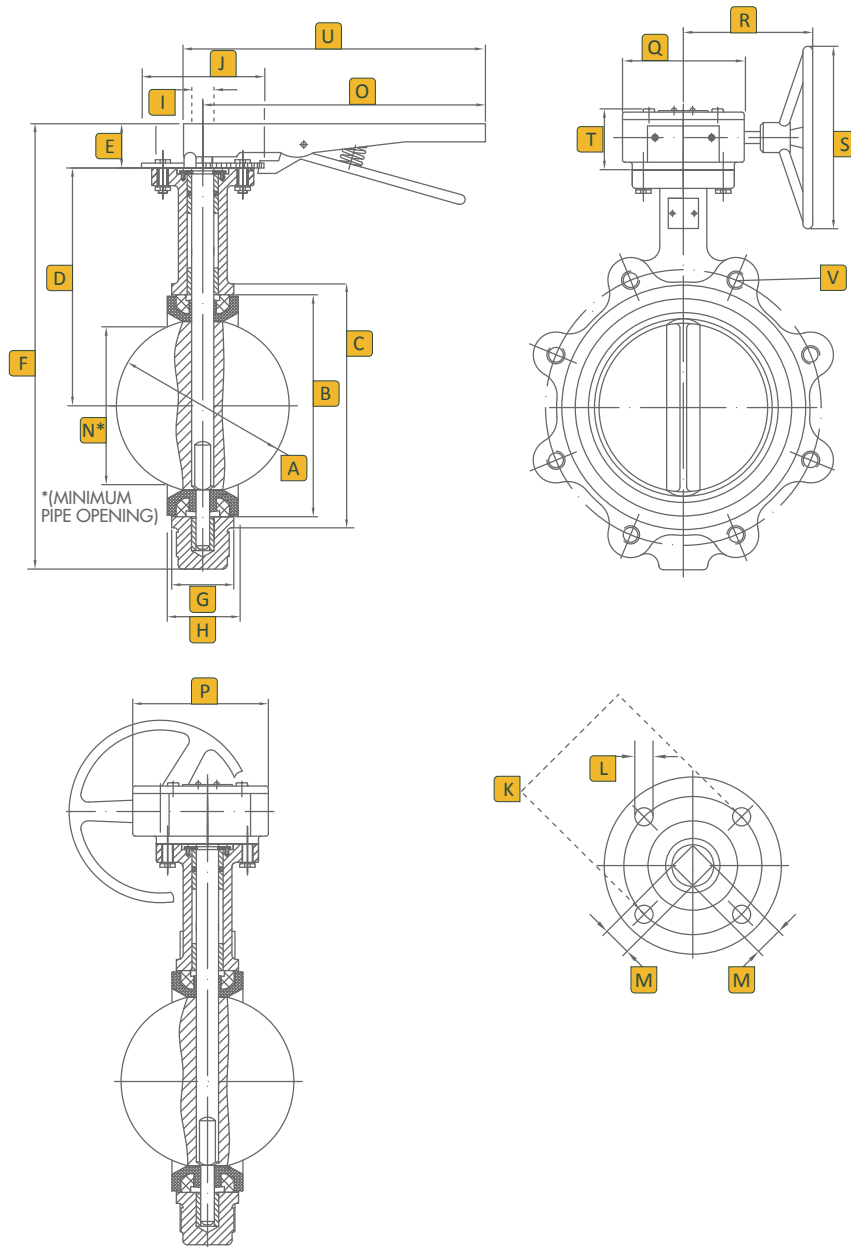

Dimensions (Inches)

Size	A	B	C	D	E	F	G	H	I	J	K	L	M	N	O	P	Q	R	S	T	U	V Lug	V Wafer
2	2.08	3.00	3.50	6.33	1.26	10.74	1.65	1.77	0.49	2.56	1.96	0.27	0.35	1.27	6.39	3.90	4.13	6.10	5.90	2.67	7.21	5/8-11 UNC	0.74
2-1/2	2.53	3.50	4.25	6.89	1.26	11.65	1.76	1.87	0.49	2.56	1.96	0.27	0.35	1.81	10.50	3.90	4.13	6.10	5.90	2.67	11.36	5/8-11 UNC	0.74
3	3.10	4.01	4.72	7.12	1.26	12.12	1.78	1.93	0.49	2.56	1.96	0.27	0.35	2.53	10.50	3.90	4.13	6.10	5.90	2.67	11.36	5/8-11 UNC	0.74
4	4.09	5.31	5.90	7.87	1.26	13.62	2.05	2.15	0.62	3.54	2.76	0.39	0.43	3.39	10.50	3.90	4.13	6.10	5.90	2.67	11.36	5/8-11 UNC	0.74
5	4.85	6.26	7.12	8.38	1.26	14.64	2.14	2.28	0.74	3.54	2.76	0.39	0.55	4.35	10.50	3.90	4.13	6.10	5.90	2.67	11.36	3/4-10 UNC	0.88
6	6.12	7.41	8.18	8.89	1.26	15.63	2.19	2.30	0.74	3.54	2.76	0.39	0.55	5.30	10.50	3.90	4.13	6.10	5.90	2.67	11.36	3/4-10 UNC	0.88
8	7.97	9.37	10.23	10.23	1.77	18.89	2.38	2.49	0.87	4.92	4.01	0.47	0.67	7.57	14.21	5.61	6.02	8.74	11.81	2.67	15.63	3/4-10 UNC	0.88
10	9.86	11.51	12.59	11.49	1.77	21.26	2.58	2.75	1.12	4.92	4.01	0.47	0.86	9.51	19.84	5.61	6.02	8.74	11.81	2.67	21.26	7/8-9 UNC	1.00

12" - 24" Dimensions

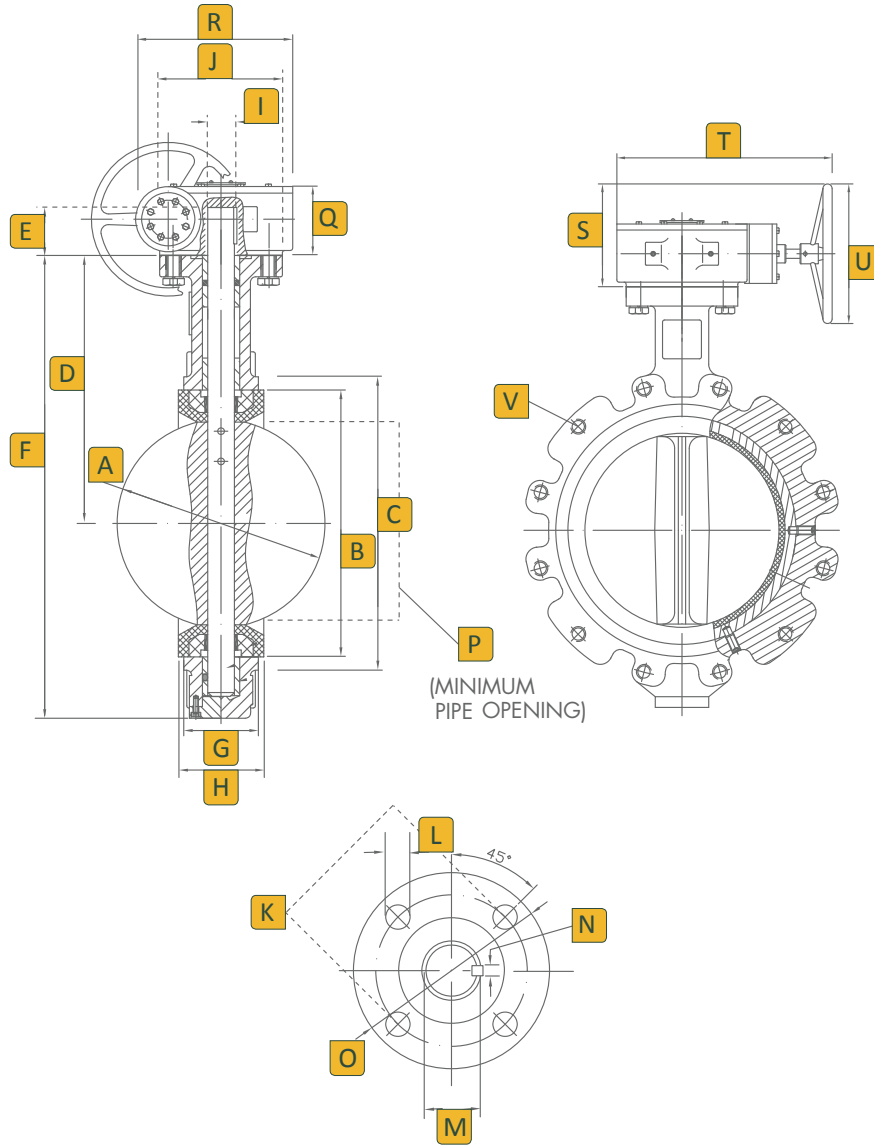

Dimensions (Inches)

Size	A	B	C	D	E	F	G	H	I	J	K	L	M	N	O	P	Q	R	S	T	U	V Lug	V Wafer
12	11.87	13.54	14.76	13.26	1.77	24.56	3.02	3.15	1.24	5.51	4.01	0.47	0.86	11.48	19.84	6.24	6.37	8.38	11.81	2.67	21.26	7/8-9 UNC	1.00
14	13.12	14.77	15.94	14.49	1.77	26.77	3.01	3.13	1.25	5.51	4.01	0.47	1.36	0.315	5.51	12.68	6.24	6.37	8.38	11.81	3.18	1-8 UNC	1.11
16	15.34	17.30	18.50	15.75	2.01	29.91	3.37	3.54	1.30	7.56	5.51	0.70	1.42	0.394	7.75	14.92	11.31	10.03	9.88	11.81	4.72	1-8 UNC	1.11
18	17.34	19.31	20.51	16.61	2.01	31.52	4.11	4.29	1.49	7.56	5.51	0.70	1.61	0.394	7.75	16.80	11.31	10.03	9.88	11.81	4.72	1-1/8-7 UNC	1.25
20	19.35	21.07	22.24	18.90	2.52	35.62	5.13	5.31	1.61	7.56	5.51	0.70	1.73	0.394	7.75	18.61	8.15	8.42	10.00	11.81	4.88	1-1/8-7 UNC	1.25
24	23.32	25.74	27.28	22.12	2.76	42.94	5.96	6.14	1.99	10.86	6.49	0.86	2.15	0.630	10.86	22.50	10.35	10.87	10.98	11.81	2.68	1-1/8-7 UNC	1.38

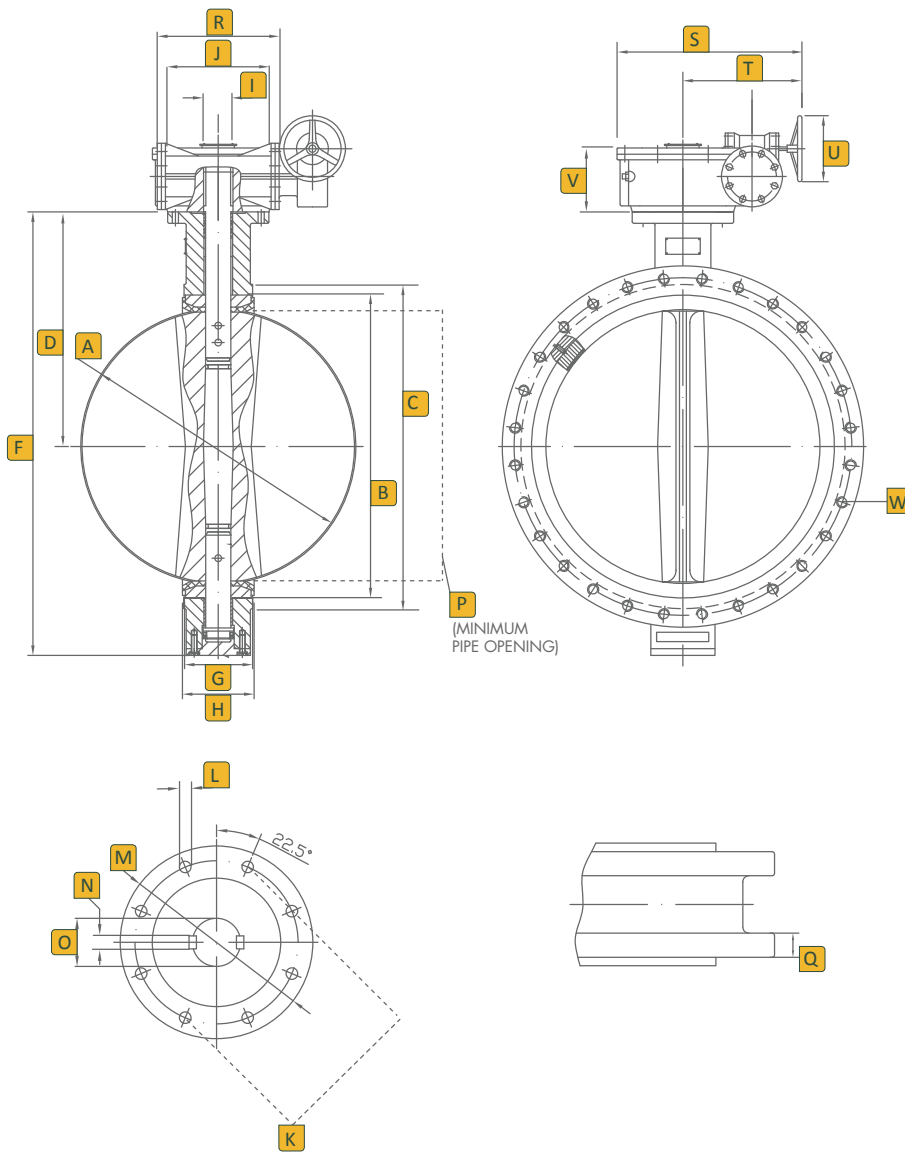

Dimensions (Inches)

Size	A	B	C	D	E	F	G	H	I	J	K	L	M	N	O	P	Q	R	S	T	U	V	W Lug
30	29.29	31.29	38.75	25.98	2.59	50.63	6.57	6.81	2.49	11.81	7.87	0.708	11.81	0.709	2.12	28.56	2.12	13.19	11.81	13.19	15.74	9.13	1-1/4-7 UNC
36	34.05	37.28	46.00	28.34	4.64	58.82	7.99	8.30	2.95	11.81	7.87	0.708	11.81	0.787	2.40	33.09	2.40	14.05	13.94	14.05	17.71	7.51	1-1/2-6 UNC
42	40.55	44.27	53.00	33.78	5.90	70.27	9.88	10.27	3.74	11.81	7.87	0.708	13.77	0.984	2.63	39.33	2.63	17.72	19.68	17.72	17.71	9.92	1-1/2-6 UNC
48	45.66	49.77	59.50	37.04	5.90	76.95	10.86	11.26	4.13	13.78	9.05	0.708	13.77	1.102	2.75	44.35	2.75	22.95	28.50	22.95	19.68	11.69	1-1/2-6 UNC

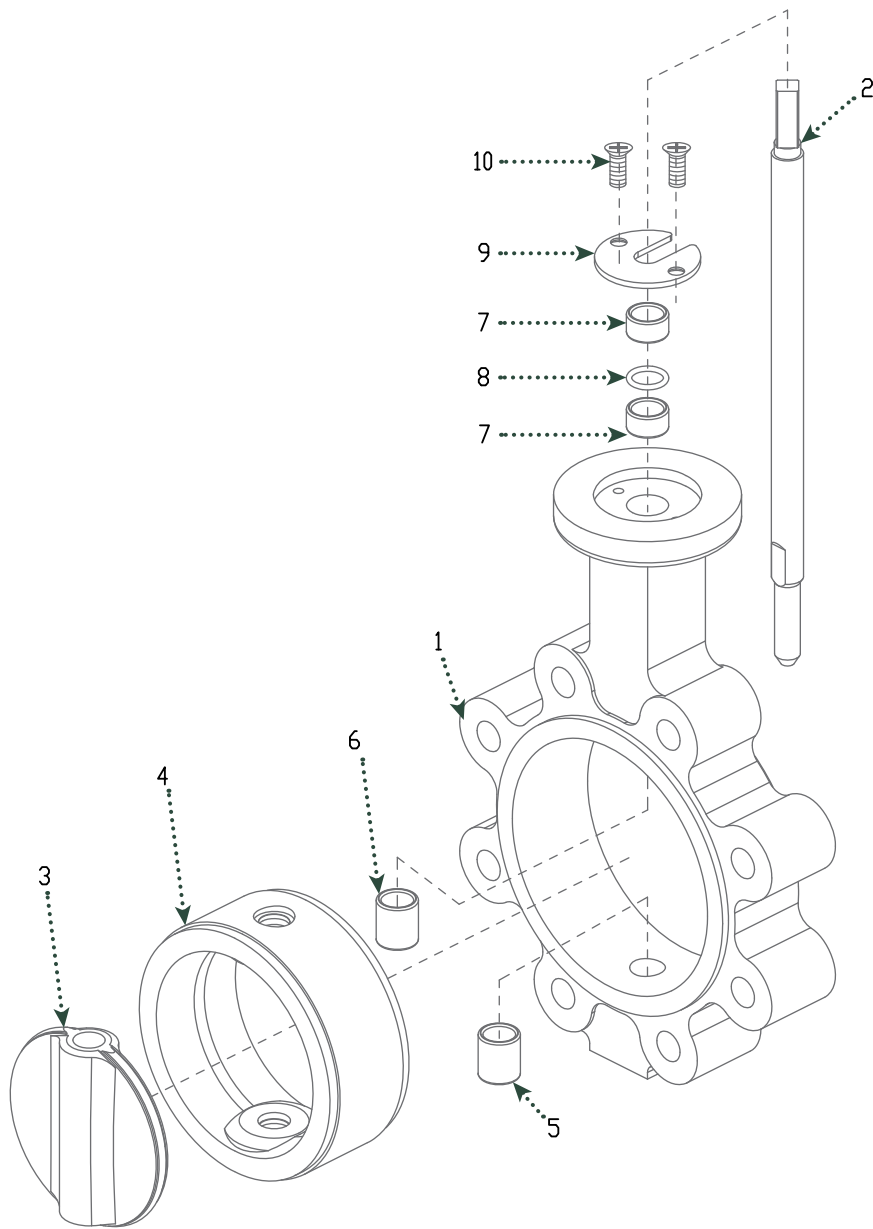

No.	Part Name	Material
1	Body	Cast Iron ASTM A126 Class B, Ductile Iron ASTM A536, Ductile Iron ASTM A395, 316 Stainless Steel ASTM A351 CF8M
2	Shaft	416 Stainless Steel ASTM A276 316 Stainless Steel ASTM A351 CF8M Monel ASTM B164
3	Disc	316 Stainless Steel ASTM A351 CF8M Aluminum Bronze ASTM B148 Monel ASTM A494 Ductile Iron Nickel Plated ASTM A536 Ductile Iron Nylon Coated ASTM A536
4	Seat	EPDM Buna-N Viton PTFE
5	Lower Bushing	Bronze ASTM A584
6	Middle Bushing	Bronze ASTM A584
7	Upper Bushing	Bronze ASTM A584
8	O-Ring	NBR
9	Retainer	Steel ASTM A283
10	Retainer Bolts	Steel ASTM A283

Size	Gear Op			CV									Torque			
	Output Lbs	Ratio	Gear Box	10°	20°	30°	40°	50°	60°	70°	80°	90°	50 psi	100 psi	150 psi	200 psi
2	1504	24:1	1 Stage	0.1	5	12	24	45	64	90	125	135	70	105	108	115
2-1/2	1504	24:1	1 Stage	0.2	8	20	37	65	98	144	204	220	100	150	136	152
3	1504	24:1	1 Stage	0.3	12	22	39	70	116	183	275	302	150	250	192	204
4	1504	24:1	1 Stage	0.5	17	36	78	139	230	364	546	600	230	260	328	352
5	1504	24:1	1 Stage	0.8	29	61	133	237	392	620	930	1022	350	530	512	548
6	1504	24:1	1 Stage	2	45	95	205	366	605	958	1437	1579	460	680	831	907
8	6195	30:1	1 Stage	3	89	188	408	727	1202	1903	2854	3136	740	1110	1527	1697
10	6195	30:1	1 Stage	4	151	320	694	1237	2047	3240	4859	5340	1330	1880	2530	2857
12	12620	50:1	1 Stage	5	234	495	1072	1911	3162	5005	7507	8250	2260	3150	3794	4338
14	12620	50:1	1 Stage	6	338	715	1549	2761	4568	7230	10844	11917	4070	5390	4870	5527
16	22126	80:1	1 Stage	8	464	983	2130	3797	6282	9942	14913	16388	5400	7120	6685	7484
18	22126	80:1	1 Stage	11	615	1302	2822	5028	8320	13168	19752	21705	6300	8750	8958	10010
20	22126	14:1	2 Stage	14	791	1674	3628	6465	10698	16931	25396	27908	8000	10800	11950	12667
24	35403	16:1	2 Stage	22	1222	2587	5605	9989	16528	26157	39236	43116	14600	20900	18680	20361
30	70806	16:1	2 Stage	35	1912	4050	8142	13152	20411	31226	47562	63328	-	-	33336	-
36	132761	16:1	2 Stage	60	3021	6063	11055	17449	26086	39731	60895	86375	-	-	46528	-
42	221268	16:1	2 Stage	93	4601	9235	16838	26575	39783	60592	92868	131725	-	-	79684	-
48	354030	20:1	2 Stage	121	5981	12001	21890	34548	51718	78770	120728	171243	-	-	111112	-

SHARPE - SERIES 17 | BUTTERFLY VALVE
 Toll Free (877) 774-2773 | Local (708) 562-9221 | Fax (708) 562-0890 | www.sharpevalves.com

Ordering

Fig: 14 - 17W - 2 - 6 - 6 - 1 - 2

Description: 14" - Wafer - Ductile Iron Body - 316 Disc & Shaft - EPDM Seat - Gear Operator

Size	Style	Body	Disc	Shaft	Seat	Operator	Options
2	14	17W Wafer	2 Ductile Iron (A356)	6 316 Stainless Steel	4 416 Stainless Steel	1 EPDM	A Memory Stop
2-1/2	16	17L Lug	1 Cast Iron	2 Nickel Plated Ductile Iron	6 316 Stainless Steel	4 Buna-N	B Stem Extension
3	18	17F Flanged	3 Ductile Iron (A395)	3 Aluminium Bronze	1 Monel	2 EPDM	C Pad Lock Handle
4	20		6 316 Stainless Steel	4 Nylon Coated Ductile Iron		3 EPDM Food Grade	D Square Nut
5	24			1 Monel		9 PTFE	E Infinite throttling with memory stop handle
6	30					7 Hypalon®	
8	36					5 Viton®	
10	42					8 High Temp Viton	
12	48						